

FAE Fagan Applicazioni Elettroniche

www.faefagan.it



VRTMT

CONTROLLER FOR AC FANS

User's manual version 04/21

This manual can be downloaded from the website: www.faefagan.it in the following languages: English, French, Spanish, Russian, German. Il presente manuale è scaricabile dal sito: www.faefagan.it nelle seguenti lingue: inglese, francese, spagnolo, russo, tedesco. Ce manuel peut être téléchargé sur le site: www.faefagan.it dans les langues suivantes: anglais, français, espagnol, russe, allemand.

Este manual se puede descargar desde el sitio web: www.faefagan.it en los siguientes idiomas: Inglés, francés, español, ruso, alemán. Dieses Handbuch kann von der Website heruntergeladen werden www.faefagan.it. Dies sind die verfügbaren Sprachen: Englisch, Französisch, Spanisch, Russisch, Deutsch. Это руководство можно загрузить с веб-сайта: www.faefagan.it Доступны следующие языки: на английском, французском, испанском, русском, немецком.

Instructions for rapid programming

1013

Instructions for language:

- 1) Turn ON the power supply
- 2) Press the button **ESC**, on the keyboard appears the word "LANGUAGE" followed by "english".
- 3) To change the language press **ENT**. The display shows "english" between two parentheses. At this point press the arrows **↑ ↓** until you reach the desired language.
- 4) Confirm your selection by pressing the button **ENT**.
- 5) Return to the status menu by pressing the button **ESC**.

Loading basic settings:

- 1) Turn ON the power supply
- 2) Turn ON the keyboard by pressing simultaneously the key **ENT** and the key **↓**
- 3) If the display shows "CYCLE COOL" you are correctly entered the menu of the working parameters.
- 4) Click the button **↓** until the display shows the message "PIN".
- 5) Now press the button **ENT** that will show the four digit pin between two parentheses, indicating the possibility of change.
- 6) Click on the button **↑** increasing the number of pins up to 0023. Then confirm with the key **ENT**.
- 7) Keyboard It now says "BASIC SETTINGS". Confirm again with the key **ENT**.
- 8) The screen now shows the word as the title "preset." Confirm with the key **ENT**.
- 9) You will see a code consisting of letters and numbers corresponding to the first preset. Scroll through the list by pressing **↓** until he appears in the display the code corresponding to the desired configuration (see user's manual on page 22) and confirm with the key **ENT**. Appears in the display for a few seconds the message "... loaded."
- 11) Now press **ESC** until the status menu will appear where "Press.", "Temp" or "Voltage" on the basis of pre-loaded system. In the event that the wiring has not yet been completed and the machine is not in use, you may receive an error message that will disappear when the problem is resolved mentioned.
(Eg.: "ERROR lack probe" will disappear when a probe pressure / temperature will be connected to the controller).

Instructions for duty cycle:

- 1) Turn ON the power supply
- 2) Turn on the keyboard by pressing simultaneously the key **ENT** and the key **↓**
- 3) If you see the word "CYCLE COOL" you have successfully entered the menu of the working parameters.
- 4) Press **ENT** to enter the menu containing the adjustable parameters and press **↓** until the parameter you want to change.
- 6) Press **ENT**. The numeric value will be displayed in round brackets (for ex. [20]), at this point using the arrow **↑** or **↓** you can increase or decrease the value to reach the desired one.
- 7) Confirm the value with the key **ENT**. Then press the button **ESC** 2 times to reach the initial screen of the status menu.

INDEX

1. PRELIMINARY INSPECTIONS - WARRANTY	3
2. VRTMT – USE FEATURES.....	4
2.1 Coding	4
3. TECHNICAL CHARACTERISTICS	4
4. MECHANICAL INSTALLATION	5
5. ELECTRICAL INSTALLATION	6
5.1 LED Warning signals.....	7
5.2 Panoramic View Cards	7
5.3 Controls Terminal Board	9
6. STATE MENU	10
6.1 State window boxes.....	10
6.2 Language Setting.....	12
7. FUNCTION CONDENSER/CHILLER.....	12
7.1 Parameters Reading and Editing.....	12
7.2 Cooling Cycle Parameters [CO1] - CHILLER.....	13
7.3 Heating Cycle Parameters [HEA] – HEAT PUMP	13
8. FUNCTION DRY COOLER.....	14
8.1 Parameters Reading and Editing.....	15
8.2 Cooling Cycle Parameters [CO1] – DRY COOLER.....	15
8.3 Heating Cycle Parameters [HEA] – DRY COOLER	16
9. OPERATING PARAMETERS - SLAVE.....	16
9.1 Parameters Reading and Editing.....	17
9.2 Working Parameters [IC] – SLAVE.....	17
10. COMPLEMENTARY FUNCTIONS.....	18
10.1 Double speed function.....	18
10.2 Anti-icing function.....	19
10.3 Spray water / evaporative panels.....	19
10.4 Clock.....	20
10.5 Load partialization	21
11. ADVANCED FUNCTIONS	21
11.1 Variable band.....	21
11.2 Proportional Integral Function	22
12. FACTORY PARAMETERS.....	22
12.1 Basic Settings	23

12.2 Motor Settings	25
12.3 Relay Settings.....	26
12.4 Modbus Settings	26
13. DIAGNOSIS.....	26

FAE - Via Alessandro Manzoni, 1036050 Quinto Vicentino - Vicenza – Italy www.faefagan.it

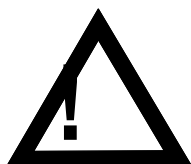

CAUTION! BEFORE INSTALLING THE *VRTMT* CONTROLLER READ CAREFULLY THE MANUAL AND FOLLOW ALL THE INSTRUCTIONS HEREIN. WITH POWERED CONTROLLER DO NOT TOUCH THE INNER ELECTRICAL PARTS IN ANY CASE. IN COMPLIANCE WITH THE EU RULES AND THE EMC DIRECTIVES, PLEASE REMIND THAT THE *VRTMT* CONTROLLER IS DESIGNED TO BE INCORPORATED ON MACHINES OR INTEGRATED ON CONTROL PANELS AND THEREFORE IS TO BE CONSIDERED AS A COMPONENT FOR PROFESSIONAL USE. THE MACHINE INSTALLATOR SHALL PROVIDE FOR THE GUARANTEE OF COMPLIANCE OF ITS EQUIPMENT TO SUCH RULES. IN THE EVENT THAT THE CONTROLLER FAILS TO OPERATE AND CAUSES DAMAGES TO THINGS OR PERSONS IT SHALL BE THE INSTALLER’S RESPONSIBILITY TO PROVIDE SAFETY DEVICES OR SYSTEMS TO PROTECT OR WARN ABOUT THE FAILED OPERATION. IN ANY MOMENT AND WITHOUT NOTICE FAE FAGAN APPLICAZIONI ELETTRONICHE RESERVES TO CARRY OUT TECHNICAL CHANGES AIMED AT ENHANCING THE QUALITY OR THE PERFORMANCE OF ITS PRODUCTS.

1. PRELIMINARY INSPECTIONS - WARRANTY

Before installing the controller, make sure that it has not been damaged during the carrying and that it corresponds to the model ordered. Check that the technical specifications listed in the label match with those written in the delivery note and in the order form. The controller is covered by a 12-month warranty starting from the delivery. The warranty covers production defects not due to damaging or wrong use, for goods returned to us EX-WORKS. Any damage occurred during the carrying shall be reported to the carrier in with the local legislation.

DISPOSAL

The sign marked on the equipment indicates that it is not to be considered as a normal domestic waste, therefore it has to be disposed of in a specific electrical and electronic equipment recycling point.

SERIAL NUMBER _____ / _____

SOFTWARE VERS. _____

2. VRTMT – USE FEATURES

The VRTMT electronic controller is normally used to control the speed of AC fans, pumps and centrifugal pumps. It is based on the principle of symmetrical phase partialisation and it is suitable for adjustable voltage motors. VRTMT operates on the basis of the inputs received through the measurements, the parameters settings values, the controlling I/O and the control panel. The control panel is used to set the parameters values and read the information about the unit status. VRTMT is provided with Modbus connection to dialog with a supervising remote device.

2.1 CODING

Position 1 2 3 4 5 6 7
VRMT 12 C PT PL 55 XX (coding example)

- Pos. 1 : Adjuster model
- Pos. 2 : Nominal current 8 = 8A, 12 = 12A, 20 = 20A...
- Pos. 3 : Power supply C= 230/400V~ 50/60Hz
D= 440/460V~ 50/60Hz (not for VRTMT8)
- Pos. 4 : Type of probe/s PT = pressure and temperature
- Pos. 5 : Container PL = plastic
- Pos. 6 : Protection grade 55 = IP55
- Pos. 7 : Variants/additions O = weekly clock, C = operable door, D = Oled display

	Power max (kVA)	Current nominal (A)	Current max* (A)	Power dissipation (W)
VRTMT 8	5,5	8	12	30
VRTMT12	8	12	23	60
VRTMT20	13	20	30	80
VRTMT28	19	28	50	120
VRTMT40	26	40	70	155
VRTMT50	32	50	70	180
VRTMT60	41	60	80	250

The data are related to operate at 400V~ 50Hz. For 230V voltage supply or VRTMTXXD models at 440-460V all current are the same.

*Max current refers to an environment temperature of 50°C for a maximum time of 10 second every 5 minutes.

3. TECHNICAL CHARACTERISTICS

POWER SUPPLY		230/400V~ +10%/-15%, (440/460V~ on demand)
FREQUENCY		50-60Hz
MAX VOLTAGE POWER OUT		>97% of power supply
OPERATING TEMP.		-25°C/+50°C (-25°C with Oled display, -20°C with lcd display)
STORING TEMP.		-40°C/+80°C
MAX TEMP.DISSIPATOR		75°C
PROTECTION GRADE		IP55 self extinguishing plastic box (ball pressure test 85°C), pollution grade 3
ELECTRIC CLASSIFICATION		Class II at the command inputs (insulation of 4kV between commands block and the device supplied parts). Class I as regards the accessible parts.
PROTECTIONS		Phase lost, inside overheating, sensor missing, external emergency (motor klixon) <u>WARNING : the regulator restores automatical.</u>
ACTION-DISCONNECTION		Protection against power surges Class II
SOFTWARE STRUCTURE		Type 1(Y). Residual current motor < 15mA
ELECTRICAL CONNECTION		Class A
		Class Y

According to safety directive, reference standard EN60730-1. According to electromagnetic directive, reference standard EN 61800-3. With refer to some typical applications, the VRTMT8-12-20 regulators are suitable for residential and commercial ambients, while the VRTMT28-40-50-60 regulators are suitable for industrial ambients. VRTMS regulators are designed to be installed inside a machine or a standard electrical cabinet and are therefore considered a component. The installer must guarantee that the machine conforms to such regulations.

4. MECHANICAL INSTALLATION

The VRTM regulator must be wall-mounted vertically, in order to guarantee adequate dispersion of heat in the area of air circulation and prevent obstructions to air flow in the dissipator zone.

VRTMT has IP55 grade protection, anyway protect it from corrosive liquids, gas, heat sources and position it preferably sheltered from the sun's rays. Make sure that it does not undergo vibrations.

Model	Weight (kg)	Dimensions (mm)			Fixed screw (mm)				Cable glands IP68 (Metric)				
		A	B	C*	D	E	F	Ø	M16	M20	M25	M32	M40
VRTMT 8	2,5	230	165	150	215	80	/	M4	1+(1)	-	2	-	-
VRTMT12	4	230	265	165	215	170	/	M4	1+(1)	1	2	-	-
VRTMT20	4,8	230	265	230	215	170	/	M4	1+(1)	1	2	-	-
VRTMT28	7	340	270	235	322	165	/	M5	1+(1)	1	-	2	-
VRTMT40	9	340	270	235	322	165	/	M5	1+(1)	1	-	-	2
VRTMT50	17	340	440	235	322	340	170	M5	1+(1)	1	-	-	2
VRTMT60	18	340	440	235	322	340	170	M5	1+(1)	1	-	-	2

C* = increase C value of 29mm with polycarbonate operable door.

(1) = hole closed with watertight plug.

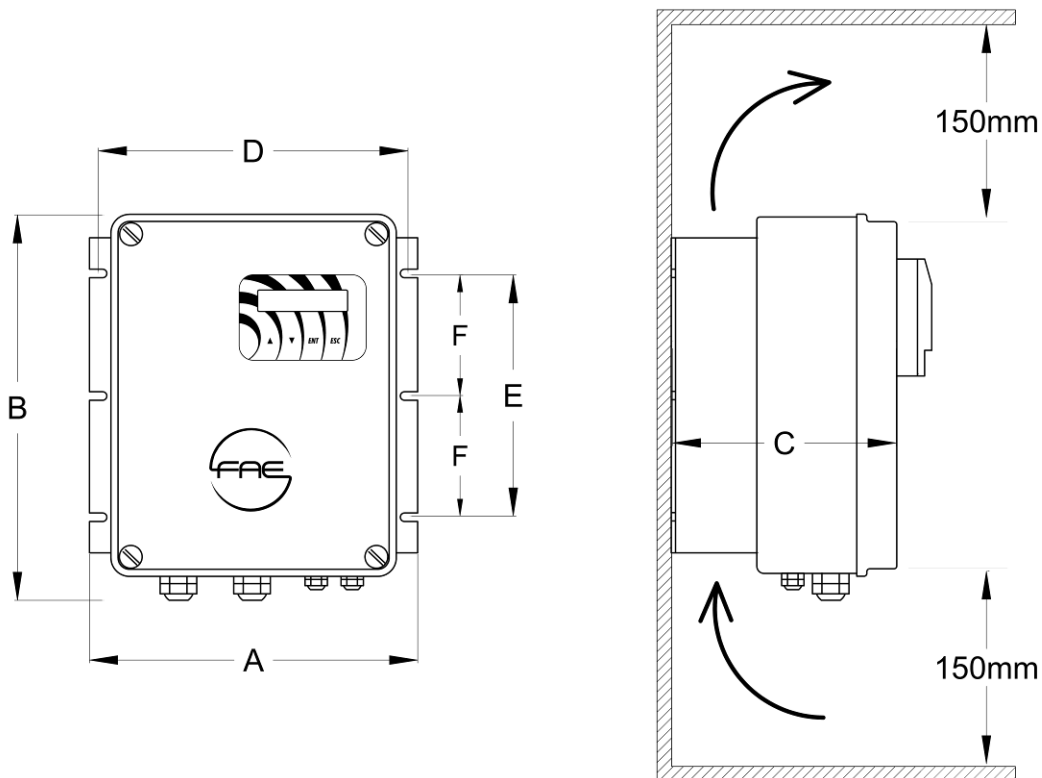

5. ELECTRICAL INSTALLATION

Loosen the screws and remove the cover completely before performing wiring. Connect the power wires and ground to the appropriate regulator terminals. Custom (+SE) Controls with ground conductor section less 10mm² require double earthing connection obtainable through the grounding of the aluminum heatsink. To avoid dispersion currents, the motor earth cable must be connected to the appropriate motor terminal ground. We recommend to connect to the machine's safety circuit any thermal motor protector in order to remove the control power supply and protect the motor with maximum efficiency. The thermal motor protector may be otherwise connected directly to the I4 control card's terminal. If the length of the motor cable exceeds 10 metres, we suggest to use shielded cable. The control load (min. current out >200mA) can consist of several engines provided the sum of the rated currents of the motors is less than 20% of the rated current of the control. We recommend not introduce any electromechanical device on the motor cable. If the control cable length exceeds 3 metres, we suggest to use shielded cable, connecting the shield only on the regulator. We suggest don't connect the control 0volt to the earth. If the length of the power, motor and control cables exceeds 10m, make sure they are separated by at least 0.3 metres to avoid creating a coupling effect.

If controls are set up in environment subject to electromagnetic disturbance, they should be housed inside a suitable metallic enclosure. In order to prevent the formation of condensation and regular working also cold temperature it is recommended you insure a constant power supply, avoiding turning it off continually.



All connections wires must resist to a 80°C working temperature. Avoid routing any electric wires near the copper coils of the filter, use the suitable plastic support ! Tighten all wires on control and power terminal boards fully down, avoiding protrusion of the multi-stranded wire.



Do NOT touch the electronic equipment when the power line is on !

During voltage insulation tests disconnect the regulator power lines In/Out.

Use a true RMS tester to measure the current or voltage values.



The cover must be closed by screwing the screws with a torque of 1.2 Nm. In the event that regulator operation failure could cause damage to objects or physical injury, it is the responsibility of the installer to add devices or systems that protect against, or warn of, control failure.

Power Supply		
C (230/400V)	230	400
D (440/460V)	440	460

Check the position of the voltage change jumper according to the supply voltage available, to the type of control (see coding paragraph page 3, pos.3) and to the panoramic view of the corresponding card.

To protect the power line and the regulator, the installation technician must install **extra-rapid semiconductor fuses upstream of the power supply adequate for the load and with a value of I²t less than the value**

given in the table below. If a differential circuit breaker is installed, it must be of the delayed action type. The regulators with rated current > 16A are in accordance to the IEC61000-3-12 on condition that the short circuit ratio R_{sc} is greater than or equal to 120 at the interface between the user power supply and the public network. For values R_{sc} minor can reduce harmonics by increasing the voltage/minimum speed.

	VRTMT8	...12	... 20	... 28	... 40	... 50	... 60
Section power cables (mm ²)	1,5 (Ls = 9)	2,5	2,5/4	6	10	16	16/25
		(Ls =12)		(Ls = 15)			
Section control cables (mm ²)	0,2÷1,5 (Ls = 9)						
Line fuses (A)	10/16	16/20	25	35	50	63	80
Extrarapid fuses (A)	16	25	32	50	63	80	100
I ² t (A ² S) max energy c.c.	610	720	720	8000	15000	15000	80000

Ls = electrical wire peeling length (mm)

To connect wiring to the spring terminals, apply leverage with a screwdriver on the lever or on the rectangular hole to open the terminal (see below the panoramic view cards). The power wires of the VRTMS50 and 60 regulators must be crimped to form an eyelet (M6 hole) and the nuts (E10) tightened with a wrench.

5.1 LED WARNING SIGNALS

DL1 : yellow, starts to flash with input signal at minimum and increases the flashing frequency as the signal rises. It goes on steady with signal = 100%. It follows the priority signal (see Basic Sett. [BS] in the Factory Parameters menu).

DL2 : green, steady ON = power supply ON.

DL3 : red, warning alarm ON:

1 flash = power phase lost.

2 flashes = external emergency.

3 flashes = internal over-temperature.

4 flashes = probe missing.

5 flashes = stop for parameters programming or error settings.

DL4 : green, flashing in modbus transmission.





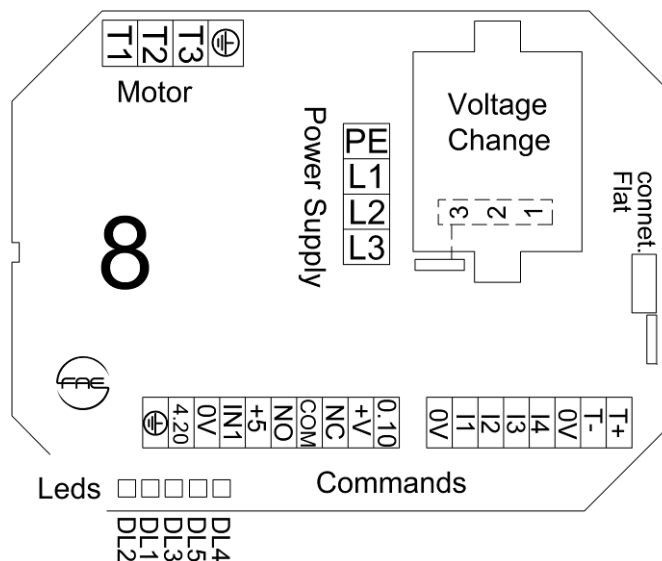

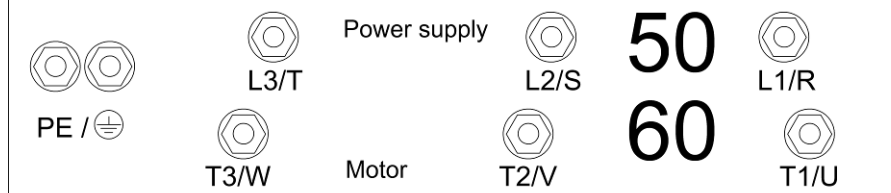
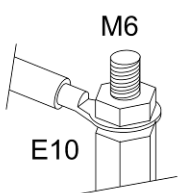
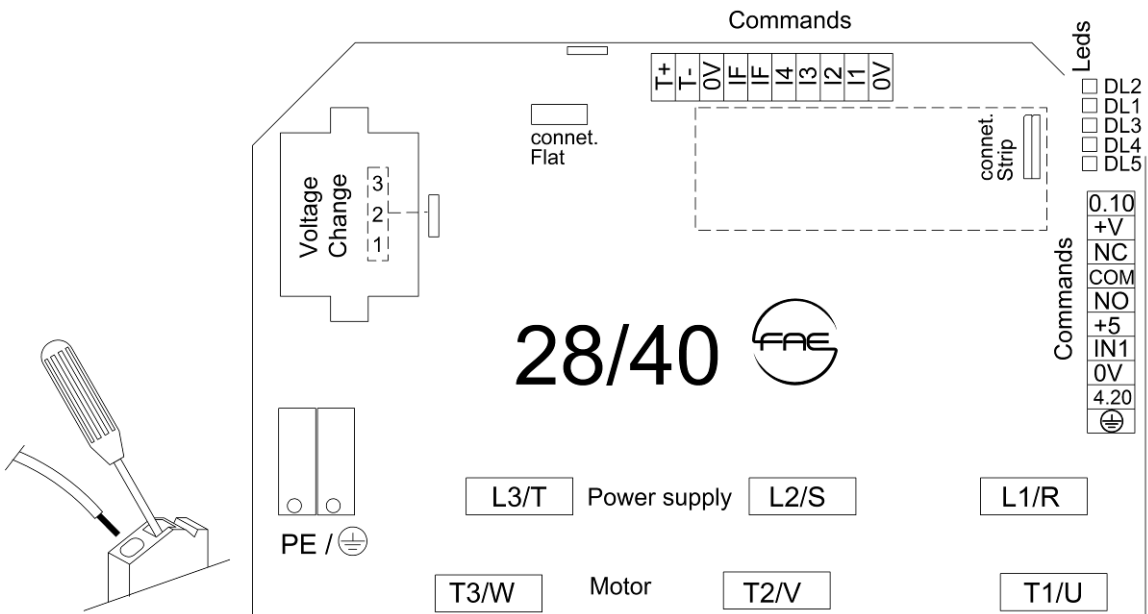
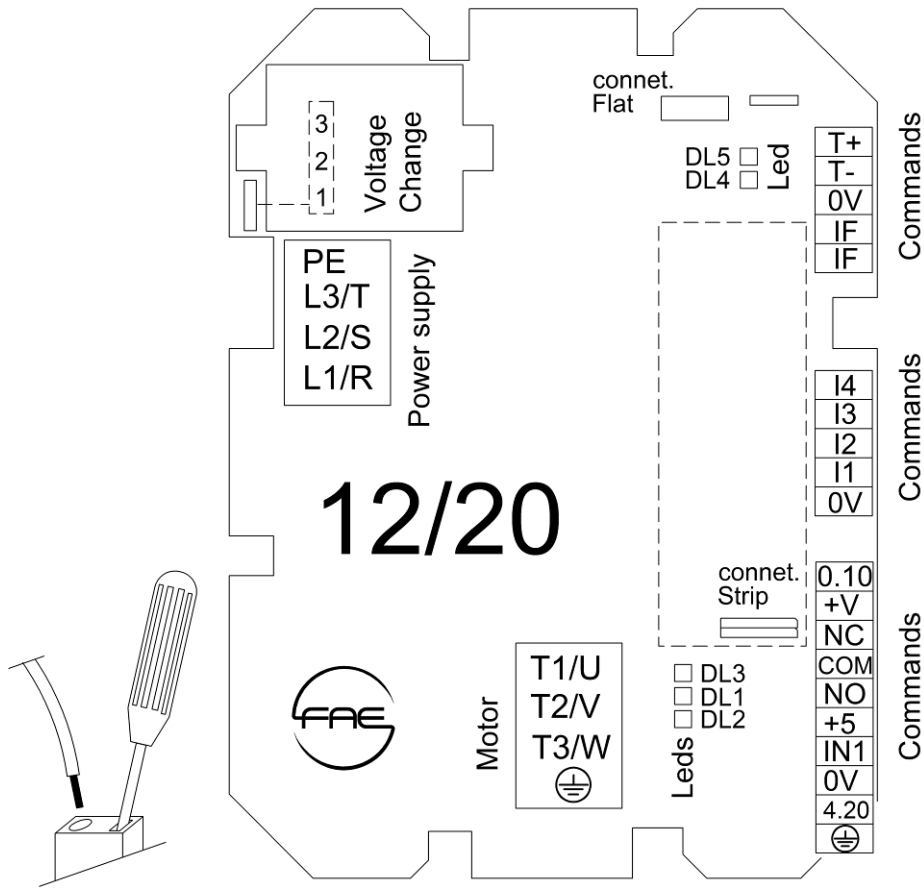
DL5 : red, flashing in modbus reception.

5.2 PANORAMIC VIEW CARDS



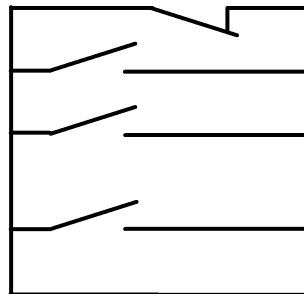

5.3 CONTROLS TERMINAL BOARD

	Term.	Description	Application	Page
	T1+	Serial RS485, Modbus RTU - Slave	Serial connection line to a Master controlled device	25
	T1 -	Serial RS485, Modbus RTU - Slave		
	0V	Ground I/O	Mass I/O	
	IF	Pwm FV, 2..20kHz input (Ri =500Ω, 5..24V))	Variable frequency command for mode slave running	22
	IF			
	I 4	External emergency input	Open immediately blocks the control. It can be connected to the load temp. protecting device/s	
	I 3	Start/Stop input	Programmable Start/Stop input	23
	I 2	Reduced Speed function input / double speed input	Closed modifies the adjusting modes. It is used for the night silenced operating or anti-icing function	17
	I 1	Direct/Reverse function input	Open enables the Cool1 cooling mode. Closed enables the Heat or Cool2 heating mode (to be set on basic sett. menu)	23
	0V	Ground I/O	Mass for the digital inputs	
	0.10	Analog input, type 0.10V (Ri = 40k Ω)	0..10V command for mode slave running (in slave mode disconnect possible pressure/temperature sensors)	22
	+V	12V power supply output = (max 30mA)	4..20mA pressure transducer power supply	24
	NC	Relay 1 closed norm. contact output		
	COM	Relay 1 common contact output (1A-250V~/3A-30V=)		
	NO	Relay 1 open norm. contact output	Programmable output. With standard setting for Defect, the relay is enabled (NO-COM eachother closed) and is disabled by turning to the position represented in the picture in emergency case.	
	+5V	5V power supply output = (max 15mA)	Ratiometric press. transd. and NTC power supply	
	IN 1	Analogical input 1, type 0,5...4,5V / ntc (10 kΩ @25°C, β3435), (Ri = 10 kΩ) / pwm 5..15V	Ratiometric pressure transducers / NTC sensor / Pwm 100Hz type with variable average value	22-23
	0V	Ground I/O	Mass for analogical input	
	4.20	Analogical input 1, type 4...20mA (Ri = 100 Ω)	4..20mA pressure transducers input, command for mode slave running (in slave mode disconnect possible pressure/temperature sensors)	23-23
	0V	Ground I/O		

CONTROL PANEL

The control panel visualizes in real time the inputs and outputs of the adjuster and allows to set the parameters. It is provided with a back-illuminated LCD/OLED display and with four keys described below.

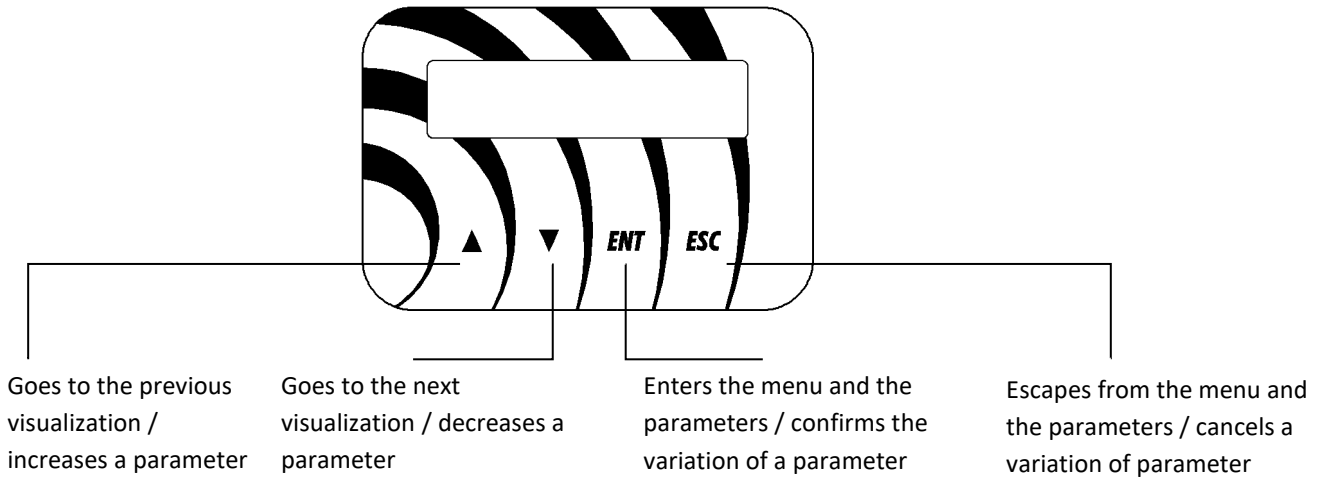

6. STATE MENU

After the device is powered the display visualizes the firmware versions of the adjuster and the keyboard. Then, if no error occurs, appears the first **state window** which visualizes the temperature or the pressure registered by input 1:

CHILLER	Press.1 [RUN] 20.3 bar [CO1]
---------	---------------------------------

RUN in operating state
FLT in block state
RDY if in Stop state

DRY COOLER	Temp.1 [RUN] 21.3 °C [CO1]
------------	-------------------------------

The cycle used for the adjusting is visualized at the right bottom: CO (COOL) or HEA (HEAT) followed by the number 1 or 2 for first or second cycle.

In this mode:

- Press the key ↓ to slide the state menu downward;
- Press the key ↑ to slide the state menu upward.

6.1 STATE WINDOW BOXES

OUTPUT 67 %

Defines the output voltage/speed. The percentage value refers from 0 to 98% of power voltage.

SLAVE	INPUT 23 %
-------	--------------------------------

INPUT 1 : Defines the percentage of the IN1 input among the following possible signals: 0..10V=, 4..20mA, pwm (100Hz type with variable average value).
INPUT PWM : Defines the percentage of the control value detected in the input dedicated to the PWM input signal with variable frequency (available only on demand).

The percentage value refers to the range defined in the basic settings, in the *PWM min* and *PWM max* parameters.

INPUT MODBUS : Defines the value transmitted by the modbus RTU to an external MASTER controller. The value is effective if included inside the range limited by the parameters *Min limit* and *Max limit* of the motor settings [IM].

MODE "chiller" *

Defines the operating mode of the adjuster:

Chiller , Dry Cooler, Slave.

This is a display-only parameter. To edit it go to the basic settings menu inside the "PREIMPO [IB]" menu.

INPUT -1 -2 -3* -4

Defines the state of the digital inputs of the terminals I1, I2, I3, I4.

An asterisk will be displayed next to the digital terminals connected to the terminal "0V".

Attention: In Slave mode the digital commands I1, I2, I3, I4 are not active.

OUTPUT RELAY -1 -2 -3*

Defines the state of the relay 1, relay 2 and relay 3. The asterisk means that they are powered and the contacts NO and COM are each other closed. The instructions 2 and 3 are displayed only with [S1 CARD OPTION].

If "Relay" is set to "Wet" (see "Relay settings" on page 25) and the asterisk flashes means that the function "Time ON" or "Time OFF" is active (see settings on page 19).

EXT. TEMP. 23.2 °C

[S1 CARD OPTION] Displays the temperature of the ambient temperature sensor connected to S1 card, expressed in degrees centigrade. If the card S1 is installed and the probe is not connected, will show " sensor miss".

VERSION 1.00

Defines the software version of the adjuster.

WED 05.09.2012 13:27:13

[WITH CLOCK OPTION]

Displays the date and time of the variable weekly clock.

This is a display-only window box.

To set the clock go to the clock menu inside the "operating parameters".

Caution: in the event of warning alarm the state window box disappears and an alarm box is displayed until the problem is solved.

ERROR! external *

Alarm warning example:

Warns about an alarm due to the control I4 open.

Other warnings refer to the alarms of: *overheating* and *probe missing*

6.2 LANGUAGE SETTING

From any screen of the operating menu press the key **ESC** to visualize the language set.

LANG.	
English	*

To change the language press **ENT** and move with the arrows **↑** **↓** until it reaches the language to set among the following available languages: *English – Italian – German – French – Spanish – Russian* [available only with OLED display].

LANG.	
->(English)	*

Press again the key **ENT** to save the setting.
The asterisk at the right bottom indicates the language set.
Press **ESC** to return to the state menu.

7. FUNCTION CONDENSER/CHILLER

The instructions in the following paragraph concerning the operation for the unit as a condenser (the control signal is one or two pressure sensors). The operating parameters base menu can be accessed from any visualization of the state menu, by pressing together the keys **ENT** + **↓** (hold the key **ENT** pressed and press the key **↓**).

CHILLER	COOL 1 SET.	[IC]

The menu windows include the menu name and the corresponding [identifying code].

The second line of the display is dotted.

- Press the key **ENT** to access the parameters of the visualized menu;
- Press the key **ESC** to return to the state menu;
- Press the key **↓** to go to the next menu;
- Press the key **↑** to return to the previous menu
-

7.1 PARAMETERS READING AND EDITING

CHILLER	P1	[IC]
	13.0	bar

The parameters windows display the name of the parameter, the [identifying code] of the corresponding menu, the value of the parameter and the unit of measure.

- **↓** to go to the parameter below;
- **↑** to go to the parameter above.

CHILLER	P1	[IC]
	->(13.0)	bar

To change the value of the parameter press **ENT**, the arrow and the value of the parameter in brackets mean that the system is in the parameter editing mode, edit the value by pressing the following key:

- **↑** to increase the value
- **↓** to decrease the value
- **ENT** to save.
- **ESC** to return to the parameter;

7.2 COOLING CYCLE PARAMETERS [CO1] - CHILLER

(example of parameterization with basic setting "mp420_50", see Factory Parameters)

CHILLER	P1 20.0	[IC] bar	Pressure of the voltage/speed V1 point. Min. 0 bar Max. P2	Def. 20 bar
CHILLER	P2 24.0	[IC] bar	Pressure of the voltage/speed V2 point. Min. P1 Max. P_MAX	Def. 24 bar
CHILLER	P_MAX 25.0	[IC] bar	Maximum production pressure, above this the output is at the voltage MotorMaxLim . Min. P2 Max. Full Scale	Def. 25 bar
CHILLER	V1 20	[IC] %	Voltage/speed of the pressure point P1. Min. MotorMinLim Max. V2	Def. 20%
CHILLER	V2 90	[IC] %	Voltage/speed of the pressure point P2. Min. V1 Max. MotorMaxLim	Def. 90%

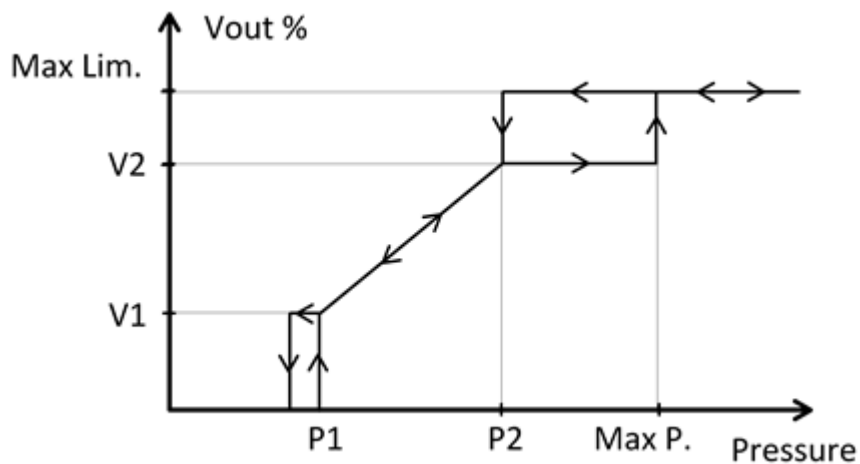

7.3 HEATING CYCLE PARAMETERS [HEA] – HEAT PUMP

(example of parameterization with basic setting "mp420_50", see Factory Parameters)

Caution: The heating cycle can be replaced by a second cooling cycle [CO2] by changing the setting of the parameter *Second Mode* (page 24).

CHILLER	P1 7.0	[IH] bar	Pressure of the voltage/speed V2 point. Min. P_MAX Max. P2	Def. 7 bar
----------------	-----------	-------------	---	------------

CHILLER	P2	[IH]
	11.0	bar

Pressure of the voltage/speed V1 point.
 Min. **P1** Max. **Full Scale** Def. 11 bar

CHILLER	P_MAX	[IH]
	5.0	bar

Maximum production pressure, below this the output is at the voltage **MotorMaxLim**.
 Min. 0 bar Max. **P1** Def. 5 bar

CHILLER	V1	[IH]
	20	%

Voltage/speed of the pressure point P2.
 Min. **MotorMinLim** Max. **V2** Def. 20%

CHILLER	V2	[IH]
	90	%

Voltage/speed of the pressure point P1.
 Min. **V1** Max. **MotorMaxLim** Def. 90%

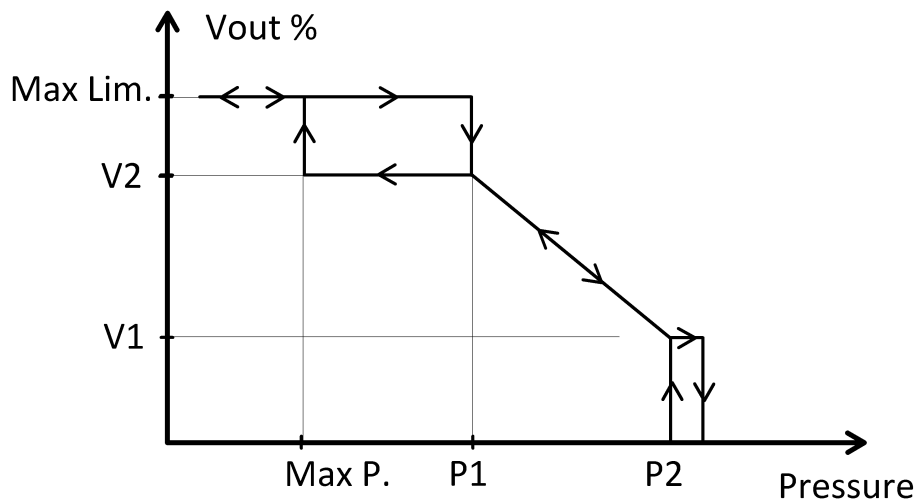

8. FUNCTION DRY COOLER

The instructions in the following paragraph concerning the operation for the unit as a dry cooler (the control signal is one or two temperature sensors placed on the output collector/s). The operating parameters base menus can be accessed from any visualization of the state menu, by pressing together the keys **ENT** + **↓** (hold the key **ENT** pressed and press the key **↓**).

DRY COOLER	COOL 1 SET.	[C1S]

The menu windows include the menu name and the corresponding [identifying code].

The second line of the display is dotted.

- Press the key **ENT** to enter the parameters of the visualized menu;
- Press the key **ESC** to return to the state menu;
- Press the key **↓** to go to the next menu;
- Press the key **↑** to return to the previous menu.

8.1 PARAMETERS READING AND EDITING

DRY COOLER	T1	[IC]
	12.0	°C

The parameters windows display the name of the parameter, the [identifying code] of the corresponding menu, the value of the parameter and the unit of measure.

- ↓ to go to the parameter below;
- ↑ to go to the parameter above.

DRY COOLER	T1	[IC]
	->(12.0)	°C

To change the value of the parameter press **ENT**, the arrow and the value of the parameter in brackets mean that the system is in the parameter editing mode, edit the value by pressing the following key:

- ↑ to increase the value
- ↓ to decrease the value
- **ENT** to save.
- **ESC** to return to the parameter;

8.2 COOLING CYCLE PARAMETERS [CO1] – DRY COOLER

(example of parameterization with basic setting "mtNTC_L", see Factory Parameters)

DRY COOLER	T1	[IC]
	22.0	°C

Temperature of the voltage/V1 speed point.
Min. 0 °C Max. **T2** Def. 22,0 °C

DRY COOLER	T2	[IC]
	28.0	°C

Temperature of the voltage/V2 speed point.
Min. **T1** Max. **T_MAX** Def. 28,0 °C

DRY COOLER	T_MAX	[IC]
	29.0	°C

Maximum production temperature, above this the output is at the voltage **MotorMaxLim**.
Min. **T2** Max. 95 °C Def. 29,0 °C

DRY COOLER	V1	[IC]
	20	%

Voltage/speed of the temperature point T1.
Min. **MotorMinLim** Max. **V2** Def. 20%

DRY COOLER	V2	[IC]
	90	%

Voltage/speed of the temperature point T2.
Min. **V1** Max. **MotorMaxLim** Def. 90%

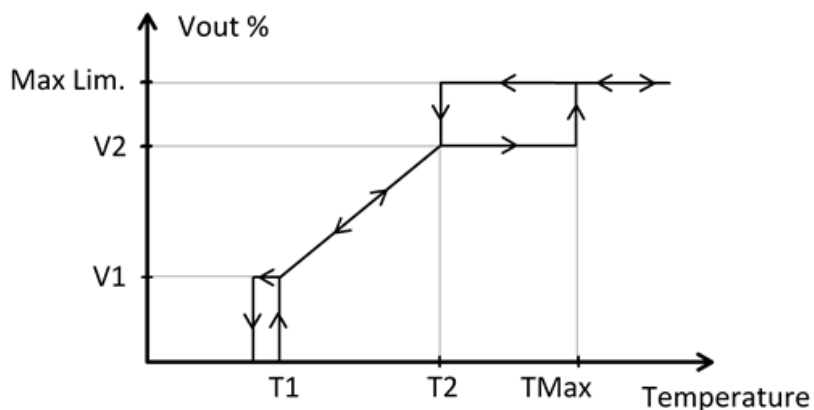

8.3 HEATING CYCLE PARAMETERS [HEA] – DRY COOLER

(example of parameterization with basic setting "mtNTC_L", Factory Parameters)

Caution: The heating cycle [HEA] for default is replaced by a second cooling cycle [CO2], to change the setting see the parameter "Second Mode" (page 24).

DRY COOLER	T1 22.0	[IH] °C	Temperature of the voltage/V2 speed point. Min. T_MAX Max. T2 Def. 22,0 °C
DRY COOLER	T2 24.0	[IH] °C	Temperature of the voltage/V1 speed point. Min. T1 Max. 95 °C Def. 24,0 °C
DRY COOLER	T_MAX 21.0	[IH] °C	Maximum production temperature, over this the output is at the voltage MotorMaxLim . Min. 0 °C Max. T1 Def. 21,0 °C
DRY COOLER	V1 20	[IH] %	Voltage/speed of the temperature point T2. Min. MotorMinLim Max. V2 Def. 20%
DRY COOLER	V2 90	[IH] %	Voltage/speed of the temperature point T1. Min. V1 Max. MotorMaxLim Def. 90%

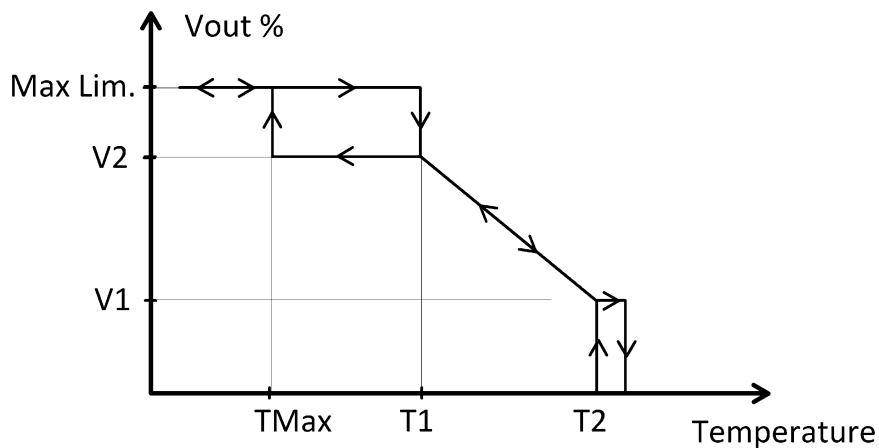

9. OPERATING PARAMETERS - SLAVE

The instructions in the following paragraph concerning the operation of the unit as "SLAVE" (with 4-20Ma/0..10V external control signal). The operating parameters base menu can be accessed from any visualization of the state menu, by pressing together the keys **ENT** + **↓** (hold the key **ENT** pressed and press the key **↓**).

SLAVE	IMPO.SLAVE [IC] -----
-------	--------------------------

The menu windows include the menu name and the corresponding [identifying code].

The second line of the display is dotted.

- Press the key **ENT** to enter the parameters of the visualized menu;
- Press the key **ESC** to return to the state menu;
- Press the key **↓** to go to the next menu;
- Press the key **↑** to return to the previous menu.

9.1 PARAMETERS READING AND EDITING

SLAVE	V1 [IC] 20 %
-------	-----------------

The parameters windows display the name of the parameter, the [identifying code] of the corresponding menu, the value of the parameter and the unit of measure.

- **↓** to go to the parameter below;
- **↑** to go to the parameter above.

SLAVE	V1 [IC] ->20 %
-------	-------------------

To change the value of the parameter press **ENT**, the arrow and the value of the parameter in brackets mean that the system is in the parameter editing mode, edit the value by pressing the following key :

- **↑** to increase the value
- **↓** to decrease the value
- **ENT** to save.
- **ESC** to return to the parameter;

9.2 WORKING PARAMETERS [IC] – SLAVE

SLAVE	MIN. INPUT [IC] 13 %
-------	-------------------------

Control signal of the Voltage V1/speed point.

Min. 10 %

Max. **InMax**

Def. 13%

SLAVE	MAX INPUT [IC] 95 %
-------	------------------------

Control signal of the Voltage V2/speed point.

Min. **InMin**

Max. 100%

Def. 95%

SLAVE	V1 [IC] 20 %
-------	-----------------

Voltage/speed of signal command IN.MINIM.

Min. **MotorMinLim** Max. **V2**

Def. 20%

SLAVE	V2 [IC] 100 %
-------	------------------

Voltage/speed of signal command IN.MAX

Min. **V1**

Max. **MotorMaxLim**

Def. 100%

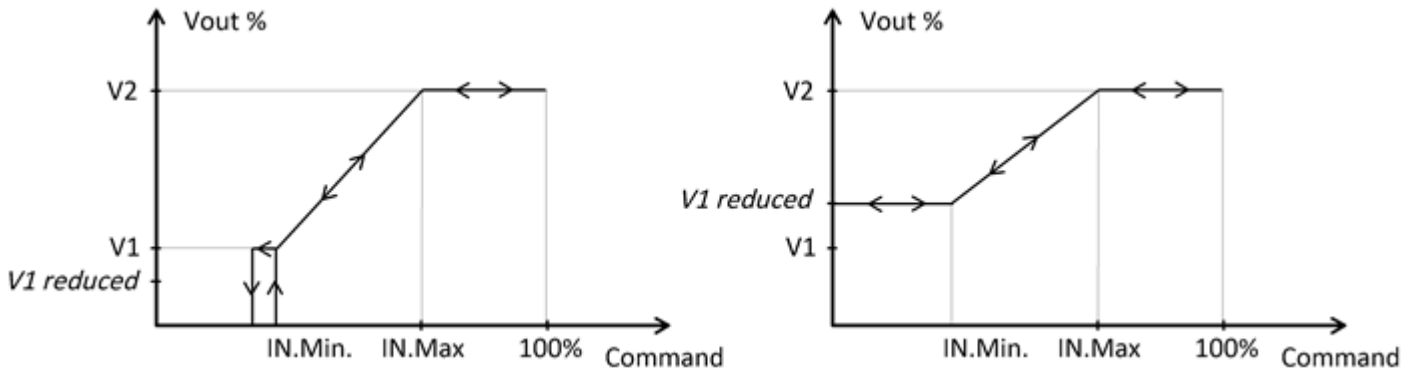

For the parameters V1 reduced and V2 reduced See "Double speed function".

10. COMPLEMENTARY FUNCTIONS

10.1 DOUBLE SPEED FUNCTION

This function is used to set a reduced maximum speed in the night, seasonal, or for a fixed speed detached from the probe signals.

Caution : With the I2 digital input closed (the clock can be used optionally) this function automatically enables the speed reduced values (V1 and V2 reduced) on all regulations and the display visualizes L^S .

V1 red.	[LV]
18	%

Voltage that replaces V1, in the cycle used, when the I2 max production contact is closed.

Min. **MotorMinLim** Max. **V2 reduced** Def. 18%

V2 red.	[LV]
65	%

Voltage that replaces V2, in the Master cycle used, when the max productions **I2 contact** is closed.

Min. **V1 reduced** Max. **MotorMaxLim** Def. 65%

ENAB W/TIME	[LV]
Off	*

[WITH CLOCK OPTION]

Allows to enable the V1 and V2 limits in the Master operating cycles, not only by closing the I2 contact, but also through the timer calendar set in the Clock menu (par 10.4).

Def. OFF

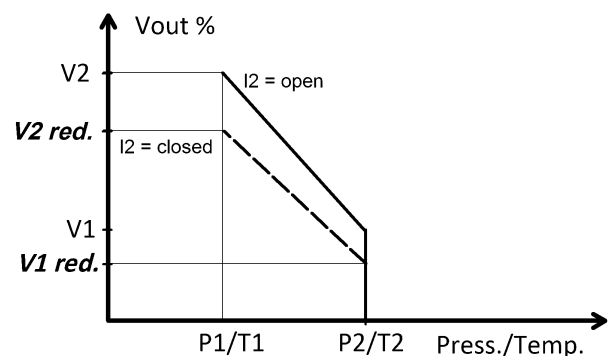
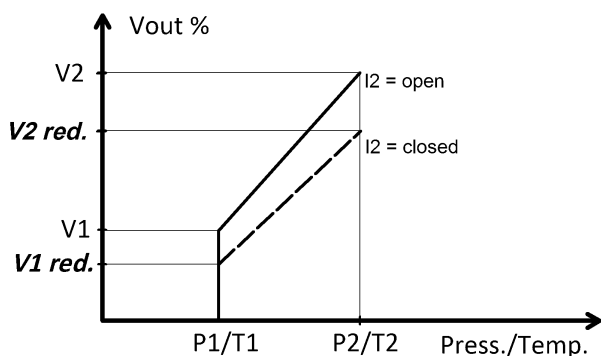

10.2 ANTI-ICING FUNCTION

This function, enable with input I2 closed (the display show L^S), allows you to maintain a minimum speed on the fans to avoid deposition of snow and possible ice formation.

[WITH CARD S1 and AMBIENT PROBE CONNECTED]: The anti-icing function is active with I2 closed and with the ambient temperature lower than 3°C.

Chiller, COOL cycle: For $V1 \text{ red.} > V1$, if the pressure/temperature is lower than P1/T1, the Voltage OUT (Vout%) will be fixed at the value of the V1 red. (see for example the left below chart).

Heat pump, HEAT cycle: For $V1 \text{ red.} > V1$, if the pressure/temperature is higher than P2/T2, the voltage OUT (Vout%) will be fixed at the value of the V1 red. (see for example the right below chart).

SLAVE mode: For $V1 \text{ red.} > V1$, if the input command signal is lower than V1 red., the voltage OUT (Vout%) will be fixed at the value of the V1 red.

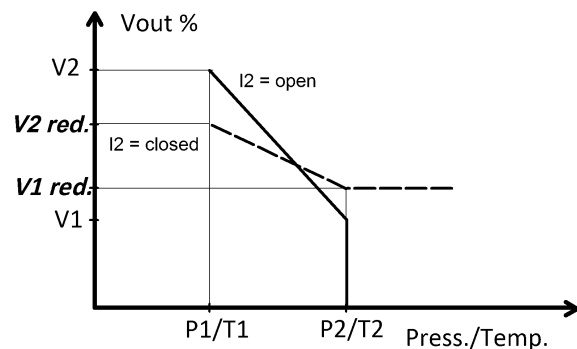
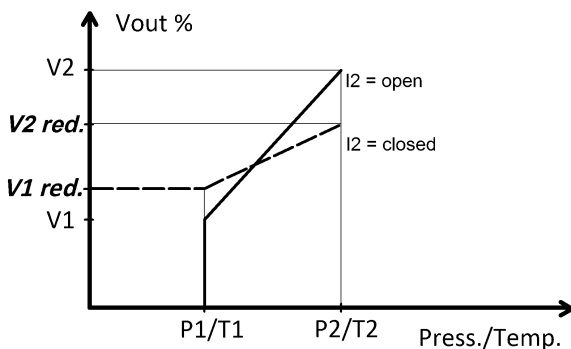

10.3 SPRAY WATER / EVAPORATIVE PANELS

[WITH CARD S1 and AMBIENT PROBE CONNECTED]: This function, is used to control a Spray water system (with pumping station) / evaporative panels controlled by a digital output (Relay 2), to use in summer temperature peaks. The system is activated upon the occurrence of constraints (settable) on the outside temperature and fan speed. This feature is already enabled by default for Relay 2. For further details see "Relay settings" on page 25.

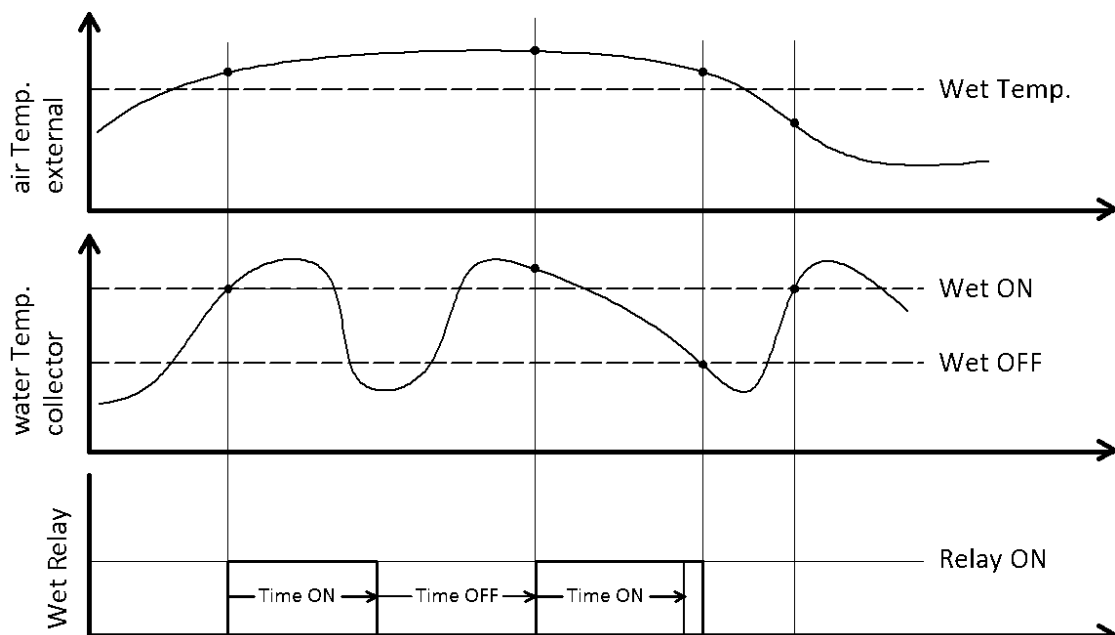

Wet temp. [IW]
27 °C

Value of the ambient temperature below which the evaporative cooling function is not active.

Min. -10°C Max. 40°C Def. 27°C

The "Wet ON" and "OFF Wet" parameters are expressed in ° C or bar depending on the setting. Here's an example of setting to "Dry cooler" applications (see parameters and graphic on page 15).

Wet ON [IW]
29,5 °C

Relay enabled over the value "Wet ON"

Min. **Wet OFF** Max. 95°C Def. 29,5°C

Caution: Set "Wet ON" to a value equal to or greater than TMAX / PMAX (see parameters on page 15 for Dry cooler and page 12 for Condensers) to ensure that the system is activated with fans speed at 100% (condition Water saving).

Wet OFF [IW]
26,5 °C

Relay disabled under the value "Wet OFF"

Min. 0°C Max. **Wet ON** Def. 26,5°C

Time ON [IW]
20 S

Min. time of activation relay

Min. 0s Max. 2500s Def. 20s

Time OFF [IW]
0 S

Min. time of deactivation relay

Min. 0s Max. 2500s Def. 0s

Wet manual [IW]
Auto

Manual function of activation / deactivation of all relays set to "Wet".

Def. automatic

Attention: The relay switch in relation to the priority probe (see "PRIORITY 'IN. [IB], page 24).

For Energy saving mode "Dry Cooler", you can set the fan speed "V" to which you want to activate the system. The "Wet ON" parameter is calculated by applying the following formula:

$$\text{Wet ON} = T1 + (V-V1) \times (T2-T1) / (V2-V1)$$

Example: With ref. the default parameters on page 15, assuming "V" = 60%, Wet ON = 22 + (60-20) x (28-22) / (90-20) = 25,4°C.

10.4 CLOCK

The following functions are available only in the controllers provided with the option O = weekly clock and only with a backup battery type CR2032-3V (not provided) as represented in the image.

The battery duration highly depends on the temperature of the environment and lasts 3 years in average. With low battery the display visualizes "b".

WED 05.09.2012
13:27:13

Displays the date and time of the internal clock.

To change press **ENT**.

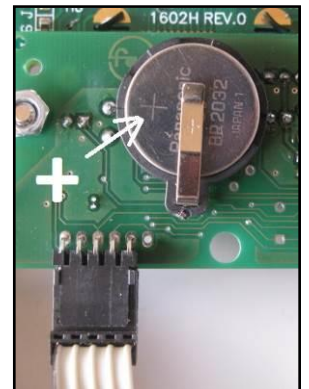

MON OFF
 --:-- → --:--

In this menu a weekly calendar can be enabled to edit the setting mode by activating the reduced speed (page18) or control the relays (page25).

MON ON
 19 : 00 → 06:00

Press the key **ENT** to enter the editing mode.

Then press **↑** and **↓** to enable (ON) or disable (OFF) the clock option of each day of the week and increase or decrease the hours and the minutes when the enabling starts and finishes. Once changed the time, the system asks to copy the setting on the next day of the week. To save press the key **ENT**, to cancel press **ESC**.

Caution: As represented in the image, if the operation start is set on the day before the day of the operation end, this will be set on the next day. Only one time can be set per day.

10.5 LOAD PARTIALIZATION

[WITH CARD S1 and AMBIENT PROBE CONNECTED]:

This feature, allows you to split the load in 2 or 3 subgroups connected to the power out through two contactors KM1 and KM2 (Class AC-2) respectively controlled by relay R2 and R3 of S1 card. To activate this function set Relay 2 and/or Relay 3 on "load." into mask "Relay" (page 25). Connect the ambient sensor after it has been adequately protected from heat, drafts and direct sunlight. If the probe detects a temperature lower than the threshold, the control will command initially only the first load connected directly and will be "hooked" the second load (Relay 2) when the first will be over 85% of its power. The same happens with the third load (Relay 3). To avoid sudden changes in the current, the adjuster will manage the restart optimally. In case the power come down below 25%, the control will "unlatch" a load at a time. The parameter T ° threshold appears only when "Relay" is set to "load."

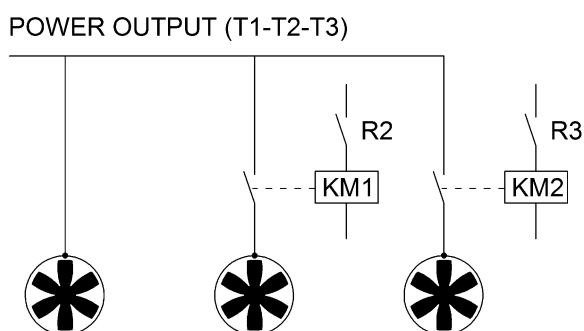

Load Limit. [IR]
 10 °C

Temperature threshold below which the load is partialized.
 Min. -15°C Max. 40°C Def. 10 °C

11. ADVANCED FUNCTIONS

PIN [PW]
 0000

To access the factory parameters menu, step down into the base parameters through the key **↓**, press **ENT**, enter the number 0023 through the key **↑**, press **ENT** to save. Down into the menu until you reach "IMP. ADVANCED".

Caution: When entering this menu, all the analogic outputs of the device will be closed and the adjusting operation will be stopped until the menu is closed.

11.1 VARIABLE BAND

[WITH CARD S2 and AMBIENT SENSOR CONNECTED]

This function, available for operating mode "Chiller and Dry Cooler in Cool mode", adapts the adjustment of the load to the temperature of the external air so that it is kept stable even with very low external temperatures. Similarly, it

allows to remain near the set point (pressure/temperature) with medium or high temperature ambient for a maximum efficiency.

BAND VAR.	[IA]
on	*

Enabling of the variable band function. (If the function is activated and the temperature probe is connected the display shows "Δ".)
Def. ON

VARIATION G	[IA]
25	%

Percentage Variation Band (G%)
Min. **20%** Max. **65%** Def. 25%

With the parameter (G%), it is possible to establish the variation of the proportional band every 5°C of deviation from the reference ambient temperature of 25°C. The variation will be an increase for lower temperatures and decreases for higher temperatures (with a minimum limit set at 2).

Ex. With reference to the "Parameters Cycle Cooling [CO1]" of page 12 (proportional band = P2-P1 = 4), and with G = 25%, imagining to work at an ambient temperature of 20 ° C, the band increases of $4 \times 0,25 = 1$ bar, then at ambient temperature of 20°C, the control will command the load at maximum speed with a pressure of P2+1bar. If the ambient temperature drops to 15°C, the bandwidth increases by $4 \times 0,25 \times 2 = 2$ bar, then at ambient temperature of 15°C, the control will command the load at maximum speed with a pressure of P2+2bar.

11.2 PROPORTIONAL INTEGRAL FUNCTION

The **PI** function (**P**roportional – **I**ntegral) is a control system that reacts to the deviation (error) than the temperature / pressure setpoint (T1 / P1) in order to reach the setpoint value.

PI	[IA]
off	*

Enabling of the PI function
OFF (Def. for Chiller)
ON (Def. for Dry Cooler)

Time Int	[IA]
10	s

It defines the integral time.
Min. 0 s Max. 600 s Def. 10 s

Attention: The Proportional Gain (Gain P) is automatically calculated with refer to the active working cycle (with set-point T1 or P1 for the cold cycle and T2 or P2 for the hot cycle). The integral time value depend to the application and must be tested on the system under conditions of use.

12. FACTORY PARAMETERS

PIN	[PW]
0000	

To access the factory parameters menu, step down into the base parameters through the key **↓** until "PIN0000", press **ENT**, enter the number 0023 through the key **↑**, press **ENT** to save.

Caution: When entering this menu, all the analogic outputs of the device will be closed and the adjusting operation will be stopped until the menu is closed.

12.1 BASIC SETTINGS

PRESET. [IB]

Allows to load one of the settings based on the below tables. Select one setting to speed the programming up (Default = mp 420_50).

Then the single parameters can be modified anyway.

Caution: previous settings will be overwritten; as for the Master pre-settings the values of SPD1 and SPD2 will be of 20% and 90% respectively.

CHILLER	Input type	Scale	COOL			HEAT		
			P1	P2	MaxP	P1	P2	MaxP
mpRZM_20	0,5..4,5V	0..20,7 bar	8 bar	12 bar	13 bar	4 bar	6 bar	3 bar
MPRZM_34	0,5..4,5V	0..34,5 bar	13 bar	18 bar	19 bar	4 bar	6 bar	3 bar
MPRZM_45	0,5..4,5V	0..45 bar	20 bar	24 bar	25 bar	7 bar	11 bar	5 bar
mp420_15	4..20 mA	0..15 bar	8 bar	10,2 bar	10,5 bar	4 bar	6 bar	3 bar
mp420_25	4..20 mA	0..25 bar	13 bar	16,6 bar	17 bar	4 bar	6 bar	3 bar
mp420_30	4..20 mA	0..30 bar	13 bar	18 bar	19 bar	4 bar	6 bar	3 bar
mp420_45	4..20 mA	0..45 bar	20 bar	24,5 bar	25 bar	7 bar	11 bar	5 bar
mp420_50	4..20 mA	0..50 bar	20 bar	24 bar	25 bar	7 bar	11 bar	5 bar

DRY COOLER	Input type	COOL			COOL 2		
		T1	T2	MaxT	T1	T2	MaxT
MTNTC_L	10kΩ @ 25°C (β3435)	22°C	28°C	29°C	22°C	28°C	29°C
MTNTC_H	10kΩ @ 25°C (β3435)	38°C	45°C	46°C	10°C	15°C	16°C

SLAVE	Input type	IN. MIN.	IN. MAX	V1	V2
S0_10	0..10V /Pwm	13%	95%	20%	100%
S4_20	4..20mA	13%	95%	20%	100%
S_PWM FV	Pwm FV				

For Slave mode command with Modbus, see the Modbus settings menu (page 25).

REG. MODE [IB]

Q

Allows to select the motor adjusting curve.

Possible modes: **Q**= optimized for fans (Def.), **L**= linear

USER ACTIV [IB]

ON

Allows to forbid the access to the "Operating parameters" menu.

ON (Def.): allows the access

OFF: forbids the access

CHILLER INPUT TYPE [IB]

4..20 mA

Defines the type of signal used.

4-20 mA (Def.): analogical signal 4-20mA;

0,5-4,5 V: analogical signal 0,5-4,5 V=.

SLAVE IN. TYPE [IB]

0..10

Defines the type of signal used.

0-10 V (Def.): analog signal 0..10V= , or **pwm** 100Hz type with variable average value (5..15V).

pwm fv: variable frequency pwm (upon on request).

modbus: Controlled by Master controller on RTU Modbus transmission.

SLAVE	PWM min	[IB]
	2	kHz

(this parameter is displayed only if "IN.TYPE [IB]" is on pwm fv)
 Minimum input frequency used for the PWM fv input.
 Min. 2 kHz Max. **MaxPwm** Def. 2kHz

SLAVE	PWM max	[IB]
	18	kHz

(this parameter is displayed only if "IN.TYPE [IB]" is on pwm fv)
 Maximum input frequency used for the PWM fv input.
 Min. **PWMmin** Max. 20kHz Def. 18kHz

CHILLER	FS PROBE	[IB]
	30,0	bar

Defines the fullscale value provided by the probes.
 Min. 0 bar Max. 1000 bar Def. 50 bar

CHILLER	UNIT MEASUR.	[IB]
	bar	*

Defines the measurement unit visualized in the state menu and in the operating parameters. **Bar** (Def.) / **Millibar** / **Pascal** / **kiloPascal**
Caution: numbers won't be converted.

DRY COOLER	OFFSET 1	[IB]
	0.0	°C

Adjusting value of the temperature probe connected to input 1.
 Min. -5 °C Max. +5 °C Def. 0 °C

DRY COOLER	OFFSET 2	[IB]
	0.0	°C

[WITH S1 CARD]
 Adjusting value of the temperature probe connected to input 2.
 Min. -5 °C Max. +5 °C Def. 0 °C

2° MODE	[IB]
direct	*

Defines the second operating cycle (**it can be activated with I1 contact**).
Direct (Def. for Dry Cooler): first cycle COOL, second cycle COOL;
Reverse (Def. for Chiller): first cycle COOL, second cycle HEAT;

PRIORITY IN.	[IB]
Automat. In.	*

[WITH S1 CARD]
 Defines the pressure reference based on the following criteria:
Automatic in. (Def.): priority to the signal of the higher probe in the cooling cycle, of the lower probe in the heating cycle;
Minimum in.: priority to the lower signal of the two probes;
Maximum in.: priority to the higher signal of the two probes;
In.2: probe 2 (disables input 1);
In.1: probe 1 (disables input 2);

START CON.	[IB]
closed	*

Defines the operating logic of the **start (I3)** contact.
Closed (Def.): enables the adjuster (start) with the contact closed;
Open: enables the adjuster (start) with the contact open;

KICK START	[BS]
OFF	*

Enabling of the kick start. This parameter is set for loads that need a torque start to move at low speeds.
 ON (Def.): function enabled OFF: function disabled

RESET ?	[IB]
Press ENT	*

Factory settings reset: reset to standard parameters (except for the operating time of the adjuster).

Caution: once entered the reset control through the key **ENT**, the old settings will be lost and the controller will be reset according to the pre-setting MP420_50.

12.2 MOTOR SETTINGS

COS-PHI [ES]
0.8

Allows to set manually the cos-phi of the load to enhance its adjusting.
Min. 0.1 Max. 1 Def. 0.8

CosPhi auto? [ES]
OFF *

Allows to enable a function that automatically detects the value of the cos-phi of the motor and save it in the parameter *COS-PHI* (available only on demand).

Caution: the controller will restart and the output voltage will be increased gradually up to the 100% to return to the basic setting value. The whole process will be automatic and last few seconds.

MIN. LIMIT [IM]
15 %

Minimum adjustable voltage, used to limit the load minimum speed.
Min. 15 % Max. **Max.Lim.** Def. 15%

MAX. LIMIT [IM]
100 %

Maximum adjustable voltage, used to limit the load maximum speed.
Min. **Min.Lim.** Max. 100% Def. 100%

RAMP [IM]
5 sec

Time employed by the adjuster to go from 0% to 100% of the output signal 0-10V.
Min. 2 sec Max. 60sec Def. 5 sec.

SUPPRESS.1 [IM]
off *

Defines the enabling of the jump window specified in the parameters "**Sup.Min.Lim.1**" and "**Sup.Max.Lim.1**" of the adjuster. It is enabled to prevent events of mechanical resonance. Def. OFF

Caution: this is a priority function on any operating cycle.

SUP.MIN.LIM.1 [IM]
20 %

Lower voltage of the jump window.
Min. 0% Max. **Sup.Max.Lim.1** Def. 20%
(this parameter is visualized only if "Suppress.1" is ON).

SUP.MAX.LIM.1 [IM]
30 %

Higher voltage of the jump window.
Min. **Sup.Min.Lim.1** Max. **Sup.Min.Lim.2** Def. 30%
(this parameter is visualized only if "Suppress.1" is ON).

The functions "**Suppress.2**" and "**Suppress.3**" with corresponding limits operate alike the "**Suppress 1**" and are priority functions on any operating cycle.

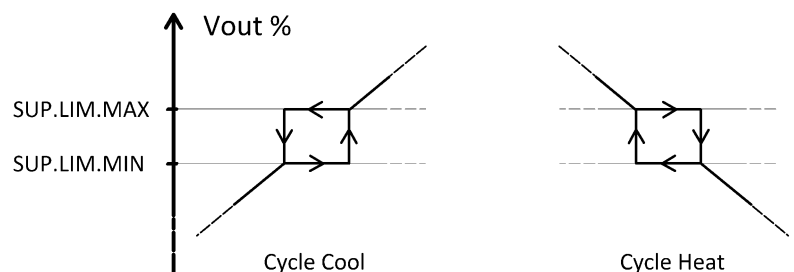

12.3 RELAY SETTINGS

RELAY	[IR]
default	*

Enables the internal relay based on the following settings:

Default (Def.) : enabled relay in a condition of regular operating, disabled relay in emergency case (see image page 9)

Wet [WITH CARD S1 and AMBIENT PROBE CONNECTED] (Def. for Relay 2): Relay enabled according to the criteria and the settings described in the chapter “Spray water/Panels Evaporative” function.

Clock [WITH CLOCK OPTION]: Relay enabled between the intervals of the clock timer. See the “Clock” chapter for the settings.

Load [WITH CARD S1 and AMBIENT PROBE CONNECTED]: Relay enabled according to the criteria and the settings described in the chapter “Load Partialization” function.

12.4 MODBUS SETTINGS

Modbus communication is always active.

MB ADDRESS	[MB]
1	

Defines the ModbusRTU address of the adjuster. It can go from 1 to 247.
Def. 1

BAUDRATE	[MB]
19200 bps	*

Defines the transmission speed on channel RS-485
Possible modes: **9600**bps, **19200**bps (Def.), **38400**bps

PARITY	[MB]
none	*

Defines the type of parity on the serial transmission.
Possibles modes: **None** (Def.), **even**, **odd**

BIT STOP	[MB]
	*

Defines the parity bit in the serial transmission.
Possible modes: **1**=one bit (Def.), **2**=two bits

SLAVE	TIME OUT MDB	[IB]	
	30		S

For the Slave mode command with Modbus, this parameter is for adjuster’s maximum time to receive the setting value on Modbus transmission. Over this time the regulator starts the analog inputs.

Min. 1 Max. 240s Def. 30s

13. DIAGNOSIS

TOTAL HOURS	[DI]
02:23	g:h

Days and hours of operation of the adjuster
Caution: in case of reset this value won’t be reset.

INT. TEMP.	[DI]
33.2	°C

Internal temperature of the adjuster represented in centigrades.

PHASE MISS.	[DI]
4	err

Quantity of stops due to the missing of a power supply phase or high disturbances in the power supply line.

OVERHEATING	[DI]
2	err

Quantity of stops due to the internal overheating.

EXTERNAL	[DI]
4	err

Quantity of stops due to an external emergency received on the terminal I4.

PROBE MISS.	[DI]
4	err

Quantity of stops due to a breakdown/fault of the possible power supply probe 4..20 mA.